



**ANALOG BOILER
CONTROLLER**

MODEL ABC 50

**INSTALLATION
OPERATION
MAINTENANCE
INSTRUCTION**

\$5.00 USA
©1997 Pulsafeeder

\$6.25 CANADA

72-500-06

ABC FACTORY SERVICE POLICY

Your ABC™ controller is a state of the art electronic based unit with on-board diagnostics. If you are experiencing a problem with your ABC™ controller, first consult the troubleshooting guide in your operation and maintenance manual. If the problem is not covered or cannot be solved, please contact our Technical Services Department for further assistance. Trained technicians are available to diagnose your problem and arrange a solution. Solutions may include purchase of replacement parts or returning unit to the factory for inspection and repair. All returns require a Return Authorization number to be issued by Pulsafeeder. Parts purchased to correct a warranty issue may be credited after an examination of original parts by Pulsafeeder. Warranty parts returned as defective which test good will be sent back freight collect. No credit will be issued on any replacement electronic parts.

Any modifications or out-of-warranty repairs will be subject to bench fees and costs associated with replacement parts.

ABC WARRANTY

Pulsafeeder, Inc. warrants ABC™ control systems of its manufacture to be free of defects in material or workmanship. Liability under this policy extends for 24 months from date of shipment. The manufacturer's liability is limited to repair or replacement of any failed equipment or part which is proven defective in material or workmanship upon manufacturer's examination. This warranty does not include removal or installation costs and in no event shall the manufacturer's liability exceed the selling price of such equipment or part. The manufacturer disclaims all liability for damage to its products through improper installation, maintenance, use, or attempts to operate such products beyond their functional capacity, intentionally or otherwise, or any unauthorized repair. The manufacturer is not responsible for consequential or other damages, injuries, or expense incurred through the use of its products.

The above warranty is in lieu of any other warranty, whether expressed or implied. The manufacturer makes no warranty of fitness or merchantability. No agent of ours is authorized to provide any warranty other than the above.



ANALOG BOILER CONTROLLER

MODEL ABC 50

CONTENTS

1. INTRODUCTION	3
2. INSTALLATION	4
3. OPERATION	8
4. ELECTRODE REMOVAL, CLEANING AND REINSTALLATION	11
5. MAINTENANCE	12
6. TROUBLE SHOOTING GUIDE	13
7. ASSEMBLY DIAGRAMS AND PARTS LISTS.	14
8. ABC SERIES LINE UP AND OPTIONS	16

1. INTRODUCTION

The Pulsafeeder ABC Controllers are used to control total dissolved solids (TDS) in steam boiler systems, in terms of electrical conductivity measured in microsiemens per cm ($\mu\text{S}/\text{cm}$). They are designed using the latest technology with plug-in circuit boards.

The units are very accurate and easy to use. This simplified design provides automated control at an economic cost.

The ABC Series comes standard with connections for AC power and blow down activation.

2. INSTALLATION

Fig. 1, Typical Installation Diagram

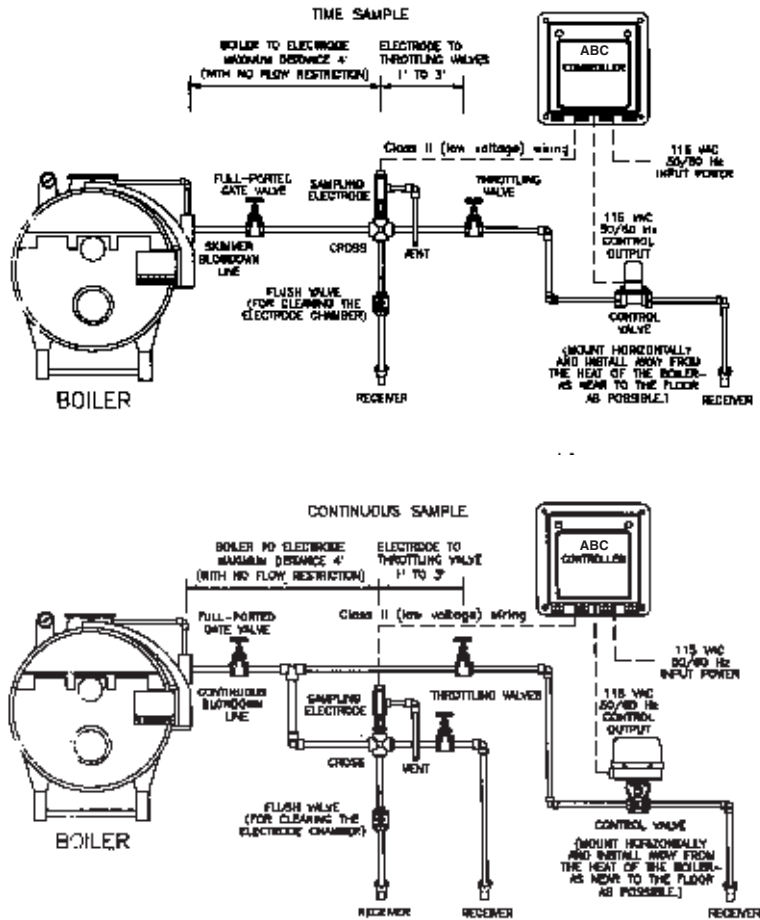

A. LOCATION:

The ABC Series Controllers are designed for ease of installation. Select a mounting location convenient to electrical and plumbing connections and easily accessible by the operator for cleaning and maintenance.

The enclosure is corrosion resistant and will stand up to most industrial environments. Be sure unit is free from vapors and liquid spills (Refer to Fig. 1, Typical Installation Diagram). Installation should comply with all national, state and local codes.

B. MOUNTING:

Mount Controller vertically on a wall or a permanent vertical support with adequate lighting and at a comfortable level (Refer to Fig. 2, Controller Dimensions).

C. ACCESSORIES:

(Available through your Pulsafeeder distributor or sales representative, but not included as standard)

Boiler Conductivity Timed Sample:

1. Blowdown valve, solenoid and strainer or motor operated ball valve.
2. Needle valve or orifice union and plates for throttling blowdown.
3. A full-port gate valve for isolation of blowdown assembly.
4. A flush valve for sensor.

Boiler Conductivity Continuous Sample:

1. Blow down valve, solenoid and strainer or motor operated ball valve.
2. Two needle valves or two orifice unions and plates for throttling blowdown.
3. A full-port gate valve for isolation of blowdown assembly.
4. A flush valve for sensor.

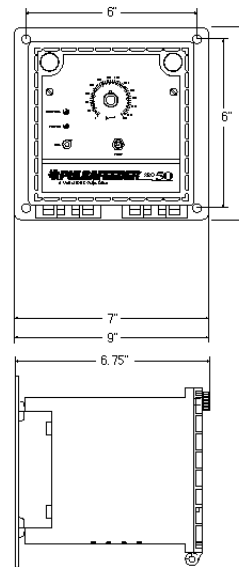

Fig. 2. Controller Dimensions

D. PLUMBING:

A flow rate of at least 1-3 gpm (gallons per minute) at the electrode is required for proper operation.

Install hand valves on both sides of electrode for easy removal and periodic maintenance.

Direction of flow should be in line with the arrow on probe assembly. Take time to review Fig. 1, Typical Installation Diagram, and note locations of hand valves, etc. for proper operation and maintenance of all components in the system loop. The throttling valve must be adjusted so that water flows across the probe, not steam.

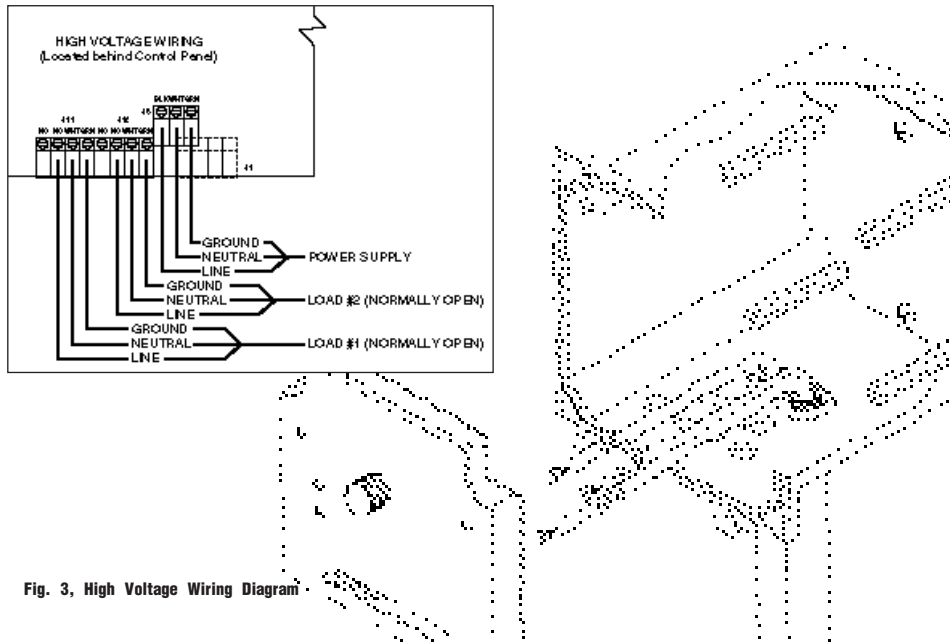

Fig. 3, High Voltage Wiring Diagram

E. ELECTRICAL:

The ABC controller has been designed to physically separate the high voltage connections from low voltage connections. Use only 16 or 18 AWG wire for conduit power and load connections.

1) High Voltage Connections:

Units must be wired by the customer, refer to Fig. 3 (also see Fig. 10) for wiring the high voltage connections. The connector JP16 is for the AC input voltage, JP4 and JP5 are relay driven AC outputs, they change simultaneously and have a maximum output of 5 amps.

The ABC 50 has two fuses for protection, a 1 amp fuse for the controller power supply, and a 5 amp fuse for the relay output. Part numbers can be found in the Trouble Shooting section.

Use the following table when connecting to JP4, JP5, and JP16:

CIRCUIT DESIGNATOR	CONNECTION TYPE
BLK or NO/NC	Line
WHT	Return
GRN	Ground

NOTE: Always use caution when making any electrical connection. Follow all applicable electrical codes. The power supply should be disconnected at the main before making any (high or low voltage) connections.

The figure at right illustrates how an actuated (motorized) ball valve, which is used for “blow down”, is connected to the ABC 50.

It employs a normally open (NO), a normally closed (NC), and common (or neutral) connections. In this example, the first device is connected at JP5. Location is behind control panel (see Figure 3).

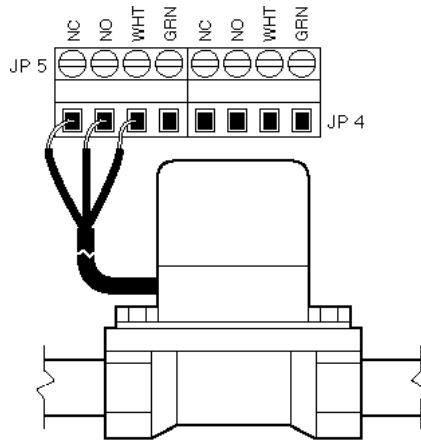

2) Low Voltage Connection:

Please refer to Fig. 4, Low Voltage Connections (located on the front of the control panel). Generally, low voltage wires are color coded to the designators printed on the front overlay. Make these connections after making the high voltage connections and re-assembling the panel to the front of the unit.

The insulation on the low voltage wires is stripped back approximately .25 inches at the factory. To attach, push in and hold the orange tab above the socket while inserting the stripped lead. Release the orange tab and pull gently on the wire to seat it in the connector and to insure a good connection.

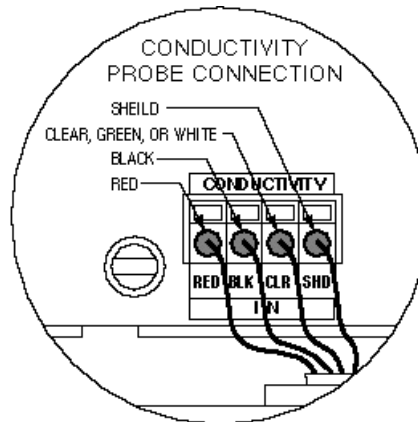

Fig. 4, Low Voltage Wiring Diagram

NOTE: Be careful not to push the wire too far into the socket such that the insulation is clamped by the connector.

CIRCUIT DESIGNATOR	CONNECTION TYPE	PROBE WIRE COLOR
RED	Probe +	Red
BLK	Probe -	Black
CLR	Probe Temp. Comp.	Clear, Green, or White
SHD	Probe Wire Shield	Silver (no Insulation)

NOTE: Do not connect the ground wire to the Shield (SHD) input. It is for the shield of the probe cable only.

NOTE: The ABC 50 does not support temperature compensation. A temperature compensated probe may be used, but will yield non-temperature compensated results.

3. OPERATION

A. CONTROLS:

Refer to Fig. 5, Front Panel Diagram and familiarize yourself with the controls of your ABC unit.

Control LED: Used for electrode calibration and to indicate conductivity trip point has been reached. (Indicates blow down solenoid relay is active).

Power LED: Indicates unit is plugged in and power is present on the circuit board.

Cal: Calibration adjustment knob used to calibrate unit conductivity.

Test Switch: Activates solenoid relay to confirm proper operation of externally connected electrical devices (eg. blow down valve). In Timed Sample Mode, the test switch initiates the blow down cycle.

Trip Point Knob/Scale: Also referred to as “set” or “control” point. Use the Trip Point knob to set desired “trip” point to activate bleed and feed. This knob and scale is also used during calibration.

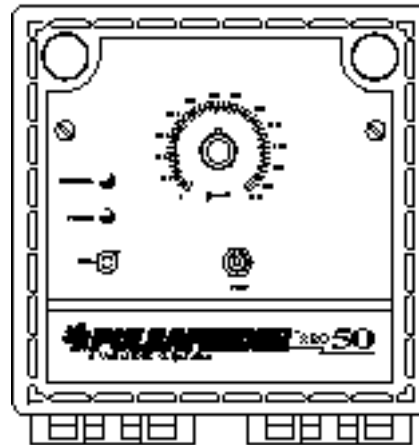

Fig. 5, Front Panel Diagram (cover in place)

B. CALIBRATION

The ABC 50 controller will require calibration periodically due to changes in temperature, and the electrodes becoming dirty. Use the test switch to force a system blow down if necessary for gathering a sample of system water.

NOTE: For best results, calibrate the ABC 50 at a conductivity as near to the trip point as possible.

- 1) Make sure unit is mounted properly and all plumbing and electrical connections are secure before applying power to the unit.
- 2) Take a sample of the boiler water and measure the conductivity with a calibrated hand held meter (Fig. 6). Take the sample at low pressure. If your hand held meter is not temperature compensated allow the sample to cool before measuring the conductivity.

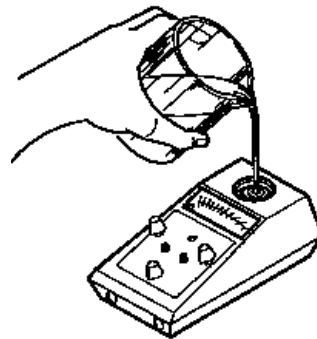

Fig. 6, Water sample reading

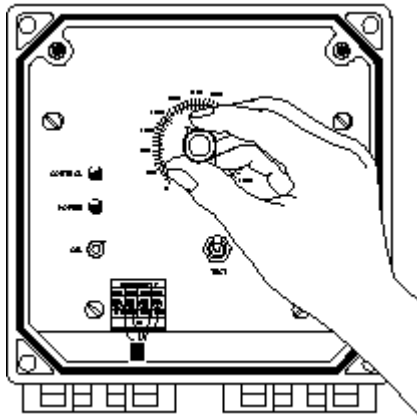

Fig. 7 Position Trip Point Knob

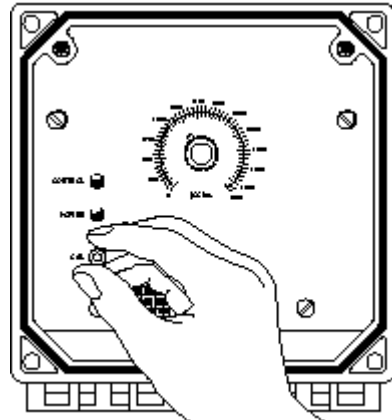

Fig. 8 Turn Cal Adjust Knob

3) Set the trip point knob to the conductivity measured by the hand held meter (Fig. 7).

4) Turn the cal knob fully counter clockwise and momentarily activate the test switch (Fig. 8). If the unit is in continuous mode you will need to wait 10 seconds before slowly turning the cal knob clockwise. If the unit is in the timed sample mode you will need to wait for the blow down interval to pass, 30 sec., 1, 2, or 4 minutes before slowly turning the cal knob clockwise. When the control led turns off stop turning the cal knob, the unit is calibrated.

C. SETTING CONDUCTIVITY TRIP POINT

1) Turn Trip Point Knob to position pointer on scale to desired trip point. (See Fig. 9)

NOTE: All standard ABC units have a differential control that has been factory set to approximately 6% of the Trip Point. This important feature prevents "chattering" (the rapid on-off switching of the relay when system conductivity hovers near the trip point).

The minimum blow down interval in Continuous Sample Mode is eight seconds to allow for full movement of a ball valve.

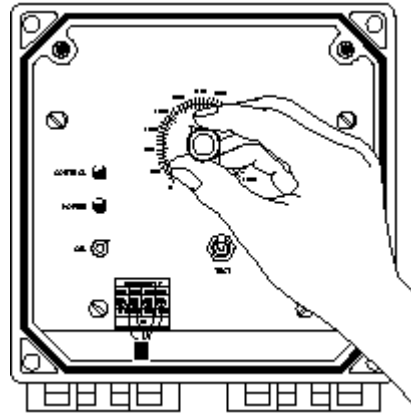
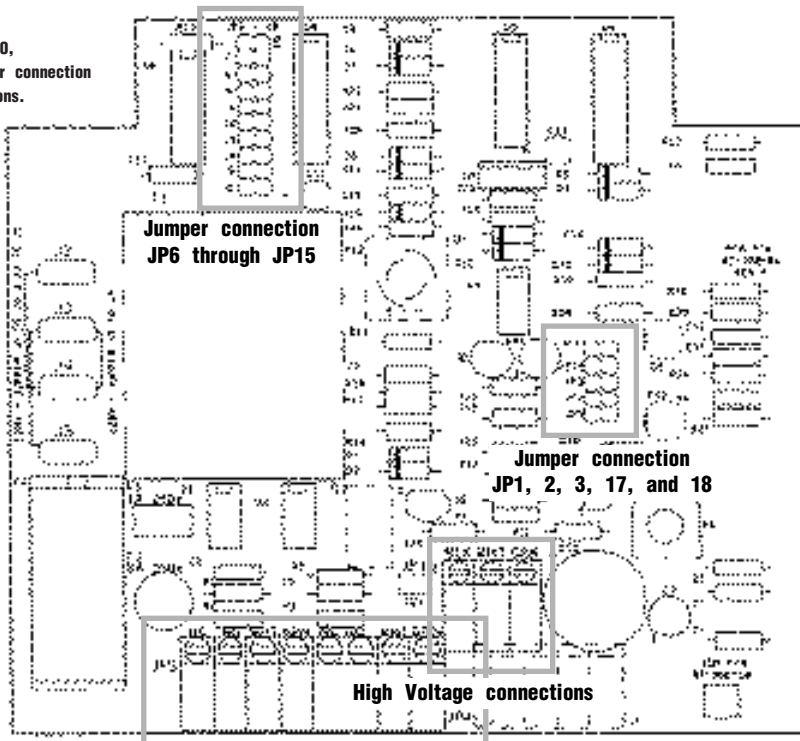

Fig. 9 Set Trip Point

D. JUMPER SELECTIONS

Fig. 10,
Jumper connection
locations.



The ABC controller can be operated in either timed or continuous mode, the ABC controller has jumpers for selection of the operating mode and the time intervals (Fig. 10).

CONTINUOUS MODE

For Continuous Mode operation, a jumper should be installed in position JP7. JP6 should be empty.

NOTE: The minimum blow down interval in Continuous Sample Mode is eight seconds to allow for full movement of a ball valve.

TIMED SAMPLE MODE

For Timed Mode operation, a jumper should be installed in JP6. JP7 should be empty. The sample intervals available are 24 hours, 8 hours, 2 hours, and 30 minutes. A jumper in JP8 selects 24 hours, JP9 selects 8 hours, JP10 selects 2 hours, and JP11 selects 30 minutes. Jumper only one of the positions JP8 through JP11. In the Timed Mode, there is a choice of 30 sec., 1, 2, or 4 minute blow down intervals. A jumper in JP15 selects 30 seconds, JP14 selects 1 minute, JP13 selects 2 minutes, and JP12 selects 4 minutes. Jumper only one of the positions JP12 through JP15.

NOTE: In the timed mode, the blow down interval will be at least the time selected. If conductivity is still above the selected trip point (after selected interval time has expired), blow down will continue until conductivity drops below the selected trip point.

JUMPER	FUNCTION	USER CHOICE
JP2, JP17	Selects 50 Hz operation	Factory installed
JP3, JP18	Selects 60 Hz operation	Factory installed
JP6	Selects Timed Sample Mode	Select either JP6 or JP7
JP7	Selects Continuous Sample Mode	
JP8	Selects a 24 hour time between sample intervals	Select one of JP8 - JP11
JP9	Selects a 8 hour time between sample intervals	
JP10	Selects a 2 hour time between sample intervals	
JP11	Selects a 30 minute time between sample intervals	
JP12	Selects a 4 minute blow down every sample interval	Select one of JP12 - JP15
JP13	Selects a 2 minute blow down every sample interval	
JP14	Selects a 1 minute blow down every sample interval	
JP15	Selects a 30 second blow down every sample interval	

4. ELECTRODE REMOVAL, CLEANING, AND REINSTALLATION

A. REMOVING THE ELECTRODE

- 1) Remove power from the controller.
- 2) Remove pressure by shutting hand valves on both sides of the electrode assembly (refer to Fig. 1, Typical Installation Diagram).
- 3) Open flush valve to drain water from the electrode piping, This will help removal of the electrode.
- 4) Unscrew electrode, and remove electrode by pulling straight out. (See Fig.11, Electrode)

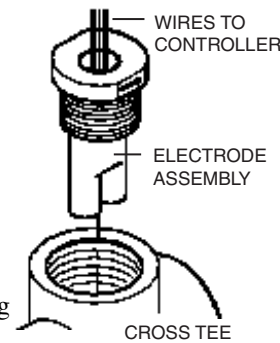

Fig. 11 Electrode

B. CLEANING ELECTRODE

- 1) Wipe the electrodes with a clean cloth. It is important to be sure to wipe the sides of the electrodes as well as the ends.
- 2) Use fine grain emery cloth for stubborn stains.
- 3) Oils can affect probe performance. Do not touch probe surface. The probe can be agitated in a mild solution of dish washing soap and water to remove oils transferred during handling.
- 4) Some fouled electrodes might require dipping in a mild solution of muriatic acid to remove fouling.

C. REINSTALLING ELECTRODE

- 1) Apply 4 wraps of Teflon tape to electrode thread. Reinstall electrode, paying attention to the arrow on the electrode for direction of flow.
- 2) Close flush valve and open hand valves to reapply pressure to the flow assembly.

NOTE: Open hand valves slowly to avoid water hammer.

- 3) Reapply power to the system and re-calibrate unit.

5. MAINTENANCE

A. SET UP A MAINTENANCE PROGRAM FOR YOUR CONTROLLER.

Normally, the electronic circuitry in the controller will not require maintenance. However, ambient temperature, humidity changes, and aging can affect the calibration of the controller. Electrodes will become dirty over a period of time and will require cleaning. The frequency of cleaning depends on the installation and the water that comes in contact with the electrode.

During the first few months of operation, check the electrode each week. This allows you to determine how often to clean the electrode. After the first few months of operation, you will be able to establish a proper maintenance schedule for your system. Check the electrode and controller calibration at least once every two months. The more frequent the maintenance, the more assurance you have of reliable controller performance.

By observing readings before and after electrode cleaning, you can determine how often to clean the electrode. If no change or only a small change in readings occurs, clean the electrode less often. If a large change in readings occurs, clean the electrode more often. See Cleaning the Electrode on page 11 of this manual.

B. ACCURACY AND READINGS

The conductivity of any solution changes with the temperature of that solution. Without some method to compensate for these changes, a unit will consist of the conductivity caused by the particular level of dissolved solids, plus or minus the effect of temperature. The ABC 50 Controller is not compensated for temperature. The user is responsible for maintaining consistent probe temperatures at calibration and during operation.

6. TROUBLE-SHOOTING GUIDE

SYMPTOM	POSSIBLE CAUSE	SOLUTION
Power light is not on	Blown fuse	Replace fuse with Bussman PCC1 (1 amp) or equivalent.
	No power supplied to unit	Check line circuit breaker.
Relay fuse blows repeatedly	External component defective	Disconnect external loads. If this prevents the fuse from blowing, plug each external load in, one-by-one, until the fuse blows. Repair or replace defective component.
	Motorized ball valve current requirements too great	Max. 5 amp resistive (Wickman 19733K, 5 amp or equivalent). Use a motor contactor to control the valve.
Control light stays on	Conductivity of water sampled is beyond range of controller	Check the conductivity of the water with a conductivity tester and compare readings.
	Probe leads shorted	Unplug probe leads, light should go off. Check lead for shorts.
	Bleed valve plugged - no bleed off	Clean or replace valve.
	Insufficient or no flow past electrode.	Remove obstruction in sample line.
	Blow down line throttled too much	Increase blow down rate.
Control light does not come on	Leaking system	Check blow down valves.
Control light goes on and off every few minutes	Electrode is air-bound	Bleed air from electrode by allowing water to completely fill and flow through it to drain. Adjust throttling valve so that only water flows across the probe. Check surface skimmer 4 to 4 inches below surface
	Poor circulation through conductivity electrode	Clean electrode.
	Bleed rate too low	Increase bleed rate.
Wide variation in solution	Bleed rate exceeds make-up water rate	Decrease bleed rate.
	Bleed rate too low	Increase bleed rate.
Conductivity of solution is slowly rising	Electrode fouled or dirty	Clean or replace electrode.
	Bleed rate too low	Increase bleed rate.
Bleed-off solenoid or other electrical device being operated by the controller does not operate.	Inoperative solenoid valve	Replace valve coil or valve as required.
	Wiring between solenoid	Rewire this connection. To check solenoid valve and control defective valve, disconnect it from the controller and energize it from a separate power source.
	Improper voltage	Check for correct valve coil voltage; should be 115 VAC. (Optional 220 VAC.)
	Improper pressure differential across solenoid valve	Check piping and pressure at your location to make sure at least the minimum pressure exists across your solenoid.

7. ASSEMBLY DIAGRAMS AND PARTS LISTS

ENCLOSURE ASSEMBLY

ITEM	QUAN.	PART #	DESCRIPTION
16	REF.	06-008-44	SCREW, 1/4-20 X, 500 LONG
15	REF.	11-037-10	INSERT, BRASS, 1/4-20
14	REF.	06-006-06	SCREW, 6-16 X, 1.00 LONG, SELF TAPPING
13	REF.	06-067-06	STANDOFF, 1/4 HEX, 1.75 LONG
12	REF.	05-057-02	KNOB, 1/4 INSERT W/ SET SCREW
11	REF.	06-151-00	SCREW, #6-32
10	REF.	03-005-18	O-RING, .441 OD, .301 ID, .070 THK
9	REF.	11-006-01	ROLL PIN
8	REF.	06-028-06	SCREW
7	REF.	11-006-09	BRACKET, WALL FLOW MTG.
6	REF.	01-060-02	ENCLOSURE
5	REF.	02-092-04	MOUNTING PANEL
4	REF.	08-986-0012	MAIN ASS'Y ABC PCB
3	REF.	02-092-00	PANEL, MAIN PCB MTG.
2	REF.	03-005-60	GASKET, ENCLOSURE
1	REF.	02-092-02	COVER, CONTROLLER

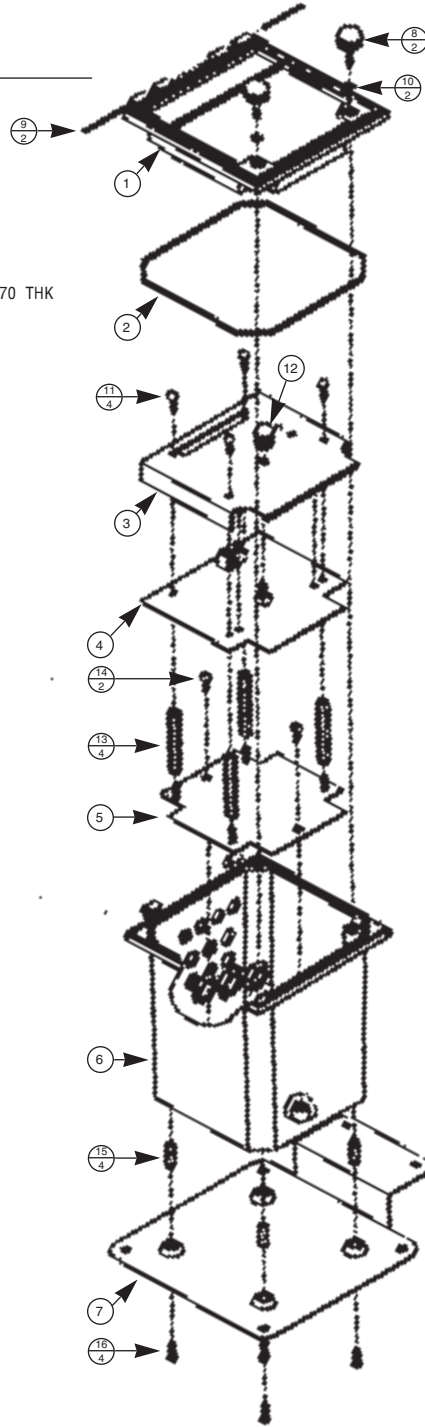

ELECTRODE ASSEMBLY

ITEM	QUAN.	PART #	DESCRIPTION
7	1	03-0132-00	CROSS, 1" 2000LBS
6	1	04-027-00	BN-1/EH-1RS BOILER PROBE
5	1	03-131-00	UNION, BOILER, 1/2" L500
4	2	03-180-00	NIPPLE, 1/2" X CLOSE, GALVANIZED
3	1	03-180-20	GASKET, ACCESS TEE, 1/2", OLKRG
2	1	03-180-10	COVER, ACCESS TEE, 1/2" OL10
1	1	03-178-00	ACCESS TEE 1/2" OT 1

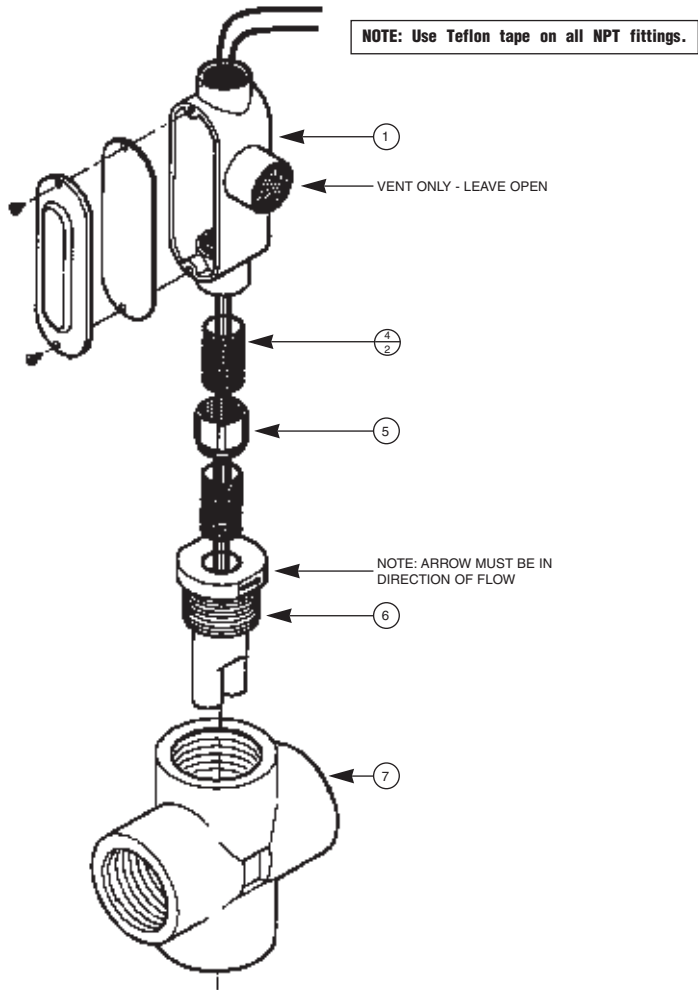

8. ABC BOILER CONTROLLER SERIES

A. KEY FEATURES:

- Front panel calibration.
- Front panel dial set point.
- Conductivity range 0-5,000 $\mu\text{S}/\text{cm}$.
- Blow down indicator LED.
- Relay test switch.
- Power indicator LED.
- Weather-tight enclosure designed to NEMA 4X.
- Wall mountable.

B. ABC MODEL STANDARD FEATURES:

ABC 50	Dial conductivity controller 0-5,000 $\mu\text{S}/\text{cm}$
ABC 101	Dial conductivity controller selectable scale 0-500, 1000, 2000, 5000, 10,000, and 20,000 $\mu\text{S}/\text{cm}$
ABC 102	Analog meter conductivity controller selectable dual scale 0-500, 1000, 2000, 5000, 10,000, and 20,000 $\mu\text{S}/\text{cm}$

C. OPTIONS:

		SERIES AVAILABLE
M-3	4-20 mA Isolated output (08-986-08)	101/102
P	230 VAC @ 50/60 Hz service	50/101/102
R	Conductivity; in-line type, max. pressure 250 psi, max. temp. 400°F (04-750-02)	50



A Unit of IDEX Corporation

27101 Airport Road
Punta Gorda, FL 33982

Toll free: 1-800-333-6677
Phone: 1-914-575-3800
Toll free Fax: 1-800-456-4085
Fax: 1-941-575-4085