



**ANALOG WATER  
TREATMENT CONTROLLER**

**MODEL ACT 50**

**INSTALLATION  
OPERATION  
MAINTENANCE  
INSTRUCTION**



A Unit of IDEX Corporation

2800 South 24th Street West  
Muskogee, OK 74401-8233

Toll free: 1-800-333-6677  
Phone: 1-918-683-0238  
Toll free Fax: 1-800-274-6677  
Fax: 1-918-683-4858

**\$5.00 USA**  
©1995 Pulsafeeder

**\$6.25 CANADA**

**72-500-00**  
10/95

## **ACT@ FACTORY SERVICE POLICY**

Your ACT™ controller is a state of the art electronic based unit. If you are experiencing a problem with your ACT™ controller, first consult the troubleshooting guide in your operation and maintenance manual. If the problem is not covered or cannot be solved, please contact our Technical Services Department for further assistance. Trained technicians are available to diagnose your problem and arrange a solution. Solutions may include purchase of replacement parts or returning unit to the factory for inspection and repair. All returns require a Return Authorization number to be issued by Pulsafeeder Electronic Control Operations (ECO). Parts purchased to correct a warranty issue may be credited after an examination of original parts by Pulsafeeder ECO. Warranty parts returned as defective which test good will be sent back freight collect. No credit will be issued on any replacement electronic parts.

Any modifications or out-of-warranty repairs will be subject to bench fees and costs associated with replacement parts. Freight will be at customer's expense.

## **ACT@ WARRANTY**

Pulsafeeder, Inc. warrants ACT™ control systems of its manufacture to be free of defects in material or workmanship. Liability under this policy extends for 24 months from date of shipment. The manufacturer's liability is limited to repair or replacement of any failed equipment or part which is proven defective in material or workmanship upon manufacturer's examination. This warranty does not include removal or installation costs and in no event shall the manufacturer's liability exceed the selling price of such equipment or part. The manufacturer disclaims all liability for damage to its products through improper installation, maintenance, use, or attempts to operate such products beyond their functional capacity, intentionally or otherwise, or any unauthorized repair. The manufacturer is not responsible for consequential or other damages, injuries, or expense incurred through the use of its products.

The above warranty is in lieu of any other warranty, whether expressed or implied. The manufacturer makes no warranty of fitness or merchantability. No agent of ours is authorized to provide any warranty other than the above.

## **FCC WARNING**

This equipment generates and uses radio frequency energy. If not installed and used properly, in strict accordance with the manufacturer's instructions, it may cause interference to radio communications. Operation of this equipment in a residential area is likely to cause interference in which case the user, at his own expense, will be required to take whatever measures necessary to correct the interference.



## **ANALOG WATER TREATMENT CONTROLLER**

# **MODEL ACT 50**

## **CONTENTS**

<b>1. INTRODUCTION . . . . .</b>	<b>3</b>
<b>2. INSTALLATION . . . . .</b>	<b>4</b>
<b>3. OPERATION . . . . .</b>	<b>7</b>
<b>4. ELECTRODE REMOVAL, CLEANING AND REINSTALLATION . . . . .</b>	<b>9</b>
<b>5. MAINTENANCE . . . . .</b>	<b>10</b>
<b>6. TROUBLE SHOOTING GUIDE . . . . .</b>	<b>11</b>
<b>7. ASSEMBLY DIAGRAMS AND PARTS LISTS. . . . .</b>	<b>12</b>
<b>8. ACT SERIES LINE UP AND OPTIONS . . . . .</b>	<b>14</b>

## **1. INTRODUCTION**

The Pulsafeeder ACT Controllers are used to control chemical feed systems that continuously protect water cooling systems from the harmful effects of scaling and corrosion. They are designed using the latest technology with plug-in circuit boards.

The units are very accurate and easy to use. This simplified design provides automated control at an economic cost.

The ACT Series comes standard with electrical receptacle cords for blow down and metering pump activation.

## 2. INSTALLATION

Fig. 1, Typical Installation Diagram

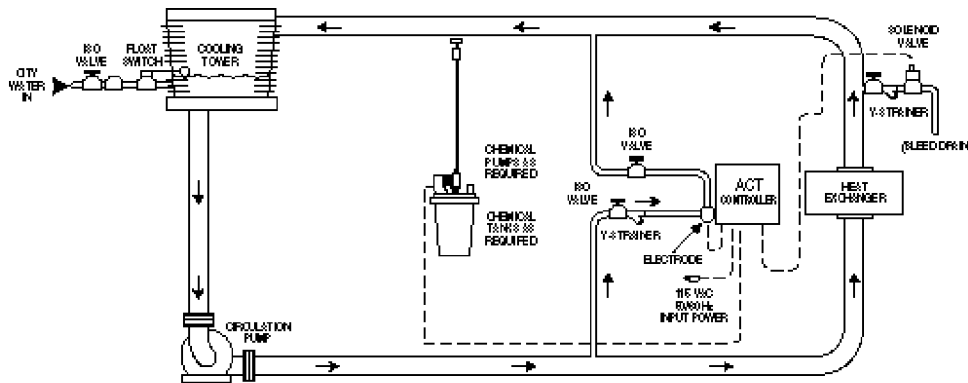

NOTE: NOT ALL EQUIPMENT SHOWN IS PROVIDED WITH ACT™ CONTROLLER, AND IS FOR REFERENCE ONLY.

### A. LOCATION:

The ACT Series Controllers are completely prewired for ease of installation. Select a mounting location convenient to electrical and plumbing connections and easily accessible by the operator for cleaning and maintenance. The enclosure is corrosion resistant and will stand up to most industrial environments. Be sure unit is from vapors and liquid spills. (Refer to Fig. 1, Typical Installation Diagram)

### B. MOUNTING:

Mount Controller vertically on a wall or a permanent vertical support with adequate lighting and at a comfortable level. (Refer to Fig. 2, Controller Dimensions)

### C. PLUMBING:

A flow rate of at least 1-3 gpm (gallons per minute) at the electrode is required for proper operation. Install hand valves on both sides of electrode for removal and periodic maintenance. Make sure electrode is installed at some point before chemical injection point and where chemical and are thoroughly mixed.

**CAUTION: Do not inject chemical up stream of probe or sensors. This will cause inaccurate readings at the controller.**

Take time to review Fig. 1, Typical Installation Diagram, and note locations of hand valves, Y-strainers, etc. for proper operation and maintenance of all components in the system loop.

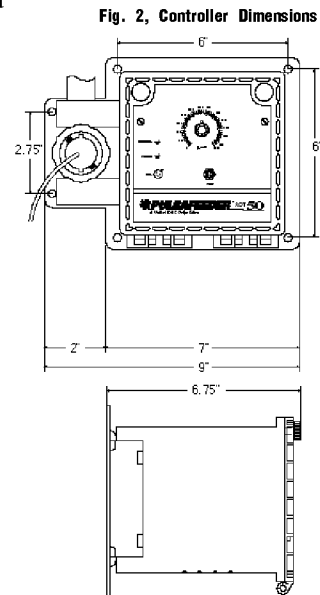

## D. ELECTRICAL:

### 1) High Voltage Connection.

**NOTE: Please use caution when making high voltage connections.**  
Refer to Fig. 3, High Voltage Wiring Diagram.

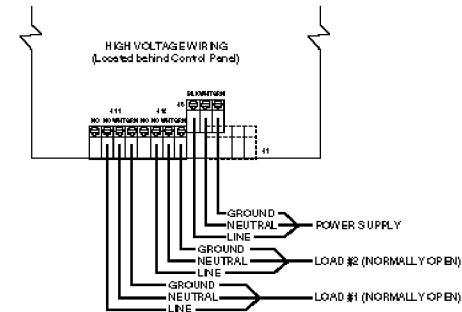

Fig. 3, High Voltage Wiring Diagram

**Pre-Wired:** Controller comes standard with pre-wired 6 ft., 18 AWG, 3-wire grounded power cord and two clearly marked 18 AWG, 3-wire receptacle cords for controlling external devices.

**Conduit:** Units ordered with Option A (Conduit) must be wired with customer supplied 18 or 16 AWG wire (18 AWG suggested) for both supply and load connections.

**Connections:** Connect the supply and loads per the following chart.

CIRCUIT DESIGNATOR	CONNECTION TYPE
BLK or NO/NC	Line
WHT	Return
GRN	Ground

Connect Supply Power to J6. Connect Load #1 (eg., blow-down solenoid valve) and Load #2 (eg., chemical metering pump) to J11 and J12 respectively. (See Figure 3 above.)

## 2) Low Voltage Connection.

Please refer to Fig. 4, Low Voltage Wiring Diagram.

**Conductivity Probe:** The conductivity probe wires are color coded to the designators printed on the probe connection receptacle. Make these connections after making the high voltage connections and re-assembling the panel to the front of the unit. The abbreviations on the receptacle relate to the probe lead colors per the following chart:

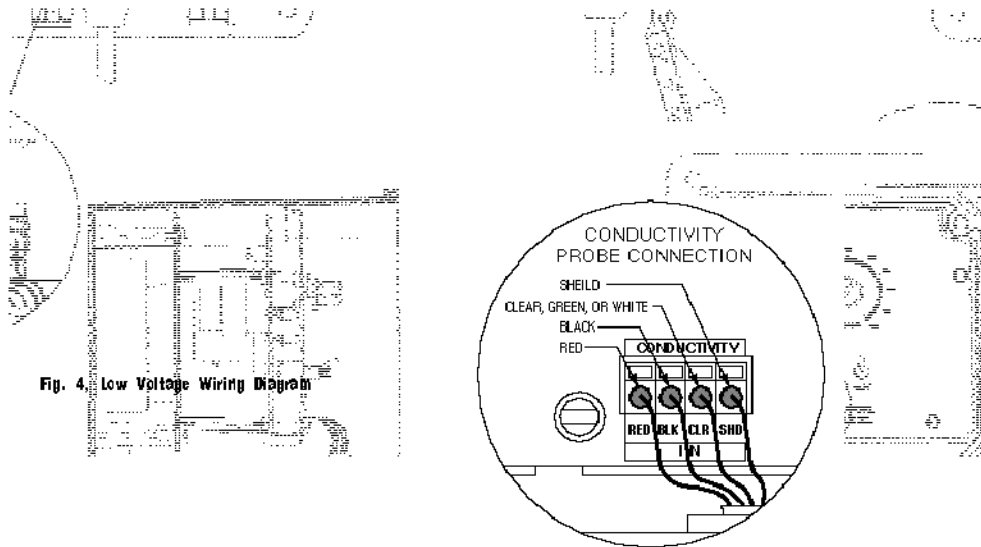

Fig. 4, Low Voltage Wiring Diagram

CIRCUIT DESIGNATOR	CONNECTION TYPE	PROBE WIRE COLOR
RED	Probe +	Red
BLK	Probe -	Black
CLR	Probe Temp. Comp.	Clear, Green, or White
SHD	Probe Wire Shield	Silver (no Insulation)

The insulation on the probe wires is stripped back approximately .25 inches at the factory. To attach, depress and hold orange tab above the hole while inserting the stripped lead into the hole. Release the orange tab and pull gently on the wire to confirm the connection is secure. Strip off enough wire insulation to make sure that connection is to the wire and not the insulation.

## 3. OPERATION

### A. CONTROLS:

Refer to Fig. 5, Front Panel Diagram and familiarize yourself with the controls of your ACT unit.

**Control LED:** Used for electrode calibration and to indicate conductivity trip point has been reached. (Indicates chemical pump and blow down solenoid relays are active).

**Power LED:** Indicates unit is plugged in and power is present on the circuit board.

**Cal:** Calibration adjustment knob used to calibrate unit conductivity.

**Test Switch:** Activates all externally connected electrical devices to check for proper operation.

**Trip Point Knob:** Also referred to as "set" or "control" point. Use the Trip Point knob to set desired "trip" point to activate bleed and feed. This knob is also used during calibration.

### B. CALIBRATION

1) Make sure unit is mounted properly and all plumbing and electrical connection are secure before applying power to the unit.

2) Take a sample of the cooling water and measure with a calibrated hand held meter. Note reading. (See Fig. 6)

*Calibration continued, next page.*

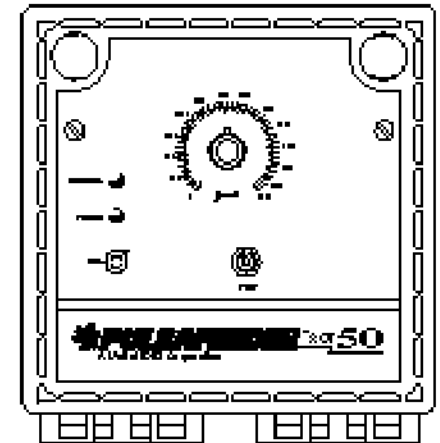

Fig. 5, Front Panel Diagram (cover in place)

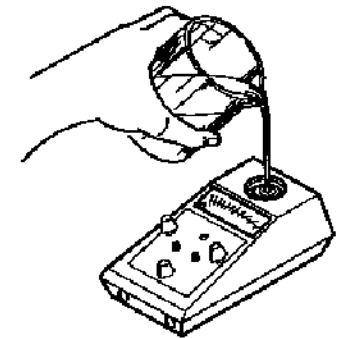

Fig. 6, Water sample reading

3) Position the Trip Point Knob (See Fig. 7) to the number on the scale that matches the value you measured with the hand held meter in step 2.

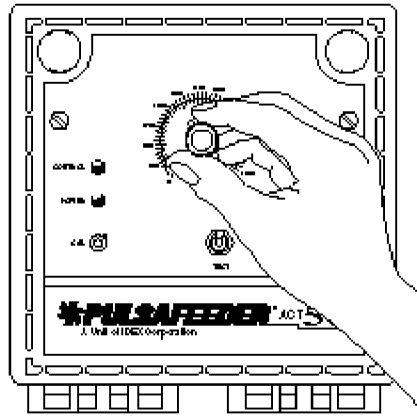

Fig. 7 Position Trip Point Knob

4) Turn Cal Adjust knob (See Fig. 8) until Control light comes on. Back off Cal Adjust knob until light just goes out. Your unit is now calibrated.

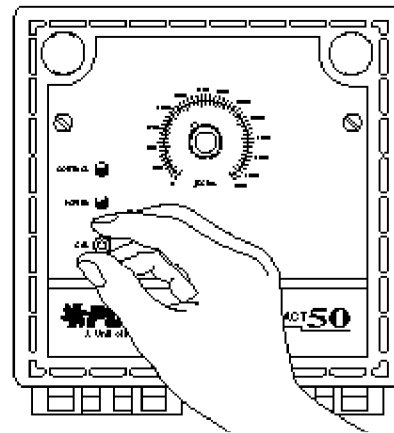

Fig. 8 Turn Cal Adjust Knob

### C. SETTING CONDUCTIVITY TRIP POINT

1) Turn Trip Point Knob to position pointer on scale to desired trip point. (See Fig. 9)

**NOTE:** All standard ACT units have a differential control that has been factory set to approximately 6% of the Trip Point. This important feature prevents @hattering@ (the rapid on-off switching of the relay when system conductivity hovers near the trip point).

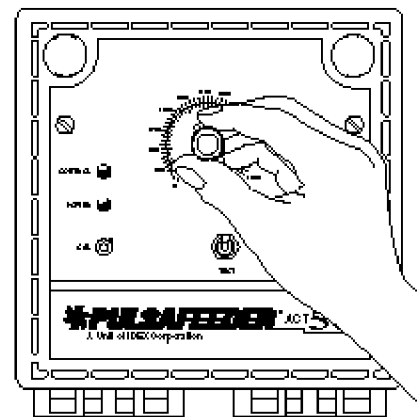

Fig. 9 Set Trip Point

## 4. ELECTRODE REMOVAL, CLEANING, AND REINSTALLATION

### A. REMOVING THE ELECTRODE

- 1) Remove pressure by shutting hand valves on both sides of the flow/electrode assembly (refer to Fig. 1, Typical Installation Diagram).
- 2) Unscrew coupling ring. Do not align slots on coupling ring with tabs on electrode housing. Grasp coupling ring and remove electrode by pulling straight out. (See Fig.10, Electrode)

### B. CLEANING ELECTRODE

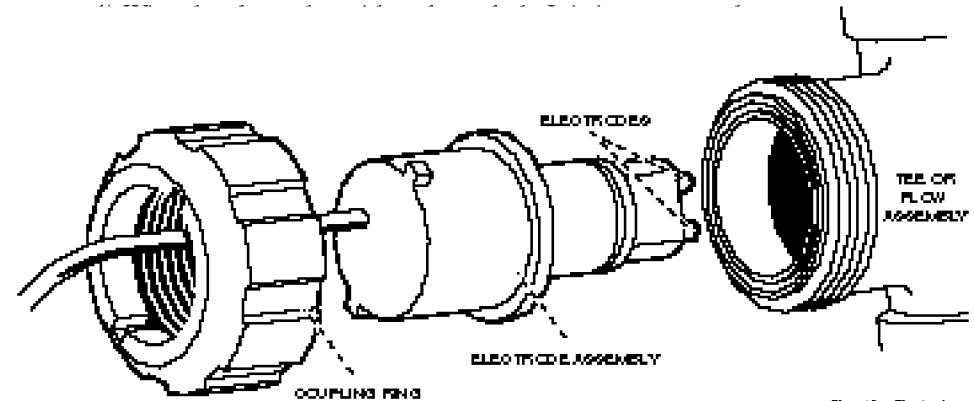

Fig. 10 Electrode

to wipe the sides of the electrodes as well as the ends.

- 2) Use fine grain emery cloth for stubborn stains
- 3) Some fouled electrodes might require dipping in a mild solution of muriatic acid to remove fouling.

### C. REINSTALLING ELECTRODE

- 1) Electrode is keyed and will only go one way into tee assembly.
- 2) Gently push electrode in to position until it fits snug in housing.
- 3) Hand tighten coupling ring only.
- 4) Close sample valve and open hand valves to reapply pressure to the flow assembly.

**NOTE:** Open hand valves slowly to avoid water hammer.

- 5) Re-calibrate unit.

## 5. MAINTENANCE

### A. SET UP A MAINTENANCE PROGRAM FOR YOUR CONTROLLER.

Normally, the electronic circuitry in the controller will not require maintenance. However, ambient temperature, humidity changes, and aging can affect the calibration of the controller. Electrodes will become dirty over a period of time and will require cleaning. The frequency of cleaning depends on the installation and the water that comes in contact with the electrode.

During the first few months of operation, check the electrode each week. This allows you to determine how often to clean the electrode. After the first few months of operation, you will be able to establish a proper maintenance schedule for your system. Check the electrode and controller calibration at least once every two months. The more frequent the maintenance, the more assurance you have of reliable controller performance.

By observing readings before and after electrode cleaning, you can determine how often to clean the electrode. If no change or only a small change in readings occurs, clean the electrode less often. If a large change in readings occurs, clean the electrode more often. See Cleaning the Electrode on page 7 of this manual.

### B. ACCURACY AND READINGS

The conductivity of any solution changes with the temperature of that solution. Without some method to compensate for these changes, a unit will consist of the conductivity caused by the particular level of dissolved solids, plus or minus the effect of temperature. The ACT Controllers are compensated to 25°C (77°F) in most water solutions.

Temperature compensation is effective across a range of 7.2° to 40.6°C (45° to 105°F). The electrode should read consistent with any accurate temperature compensated test instrument.

## 6. TROUBLE-SHOOTING GUIDE

SYMPTOM	POSSIBLE CAUSE	SOLUTION
Power light is not on	Blown fuse	Replace fuse with 3 AG Type (1 amp) or equivalent.
	No power supplied to unit	Check line circuit breaker.
Fuse blows repeatedly	External component defective	Disconnect external loads. If this prevents the fuse from blowing, plug each external load in, one-by-one, until the fuse blows. Repair or replace defective component.
	Pump current requirements too great	Maximum 5 amp resistive. Use a motor contactor to control the pump motor.
Control light stays on	Conductivity of water sampled is beyond range of controller	Check the conductivity of the water with a conductivity tester and compare readings.
	Solenoid probe leads shorted	Unplug probe leads, light should go off. Check lead for shorts.
	Valve plugged - no bleed off	Clean or replace solenoid valve.
	Insufficient or no flow past electrode.	Remove obstruction in sample line.
Control light does not come on	Overflowing or leaking system	Solenoid valve not closing.
Control light goes on and off every few minutes	Electrode is airbound	Bleed air from electrode by allowing water to completely fill and flow through it to drain.
Wide variation in solution	Poor circulation through conductivity electrode	Clean electrode.
	Bleed rate exceeds make-up water rate	Decrease bleed rate.
	Bleed rate too low	Increase bleed rate.
Conductivity of solution is slowly rising	Electrode fouled or dirty	Clean or replace electrode.
	Bleed rate too low	Increase bleed rate.
Bleed-off solenoid or other electrical device being operated by the controller does not operate.	Inoperative solenoid valve	Replace valve coil or valve as required.
	Wiring between solenoid	Rewire this connection. To check solenoid valve and control defective valve, disconnect it from the controller and energize it from a separate power source.
	Improper voltage	Check for correct valve coil voltage; should be 115 VAC. (Optional 220 VAC.)
	Improper pressure differential across solenoid valve	Check piping and pressure at your location to make sure at least the minimum pressure exists across your solenoid.
	Blown Control Relay fuse	Replace fuse with 3 AG Type, 5 amp or equivalent
Abnormal reading	Electrode fouled or dirty	Use this method to determine if the electrode is at fault. Activate the TEST Switch. The Control light should come on and all external relays should be energized (the chemical pump, solenoid valve, and/or other electrical controlled devices should be operating). If the unit has been previously recalibrated, the value read should be that which was used and recorded at that time.

# 7. ASSEMBLY DIAGRAMS AND PARTS LISTS

## ENCLOSURE ASSEMBLY

ITEM	QUAN.	PART #	DESCRIPTION
18	2	13-003-02	POWER CORD, FEMALE, 115v
17	4	06-008-44	SCREW, 1/4-20 X, 500 LONG
16	4	11-037-10	INSERT, BRASS, 1/4-20
15	2	06-006-06	SCREW, 6-16 X, 1.00 LONG, SELF TAPPING
14	4	06-067-06	STANDOFF, 1/4 HEX, 1.75 LONG
13	1	05-057-02	KNOB, 1/4 INSERT W/ SET SCREW
12	4	06-028-06	CAPTIVE PANEL SCREW, #6-32
11	2	03-005-18	O-RING, .441 OD, .301 ID, .070 THK
10	2	11-006-01	ROLL PIN
9	2	06-028-06	CAPTIVE PANEL SCREW, #1D
8	1	13-003-00	POWER CORD, MALE, 115v
7	1	11-006-09	BRACKET, WALL FLOW MTG.
6	1	01-060-02	ENCLOSURE MOUNTING PANEL
5	1	02-092-04	MOUNTING PANEL ACT 50 MAIN PCE ASSY
4	1	08-986-00	PANEL, MAIN PCE MTG.
3	1	02-092-00	GASKET, ENCLOSURE
2	1	03-005-60	COVER, ACT CONTROLLER
1	1	02-092-02	

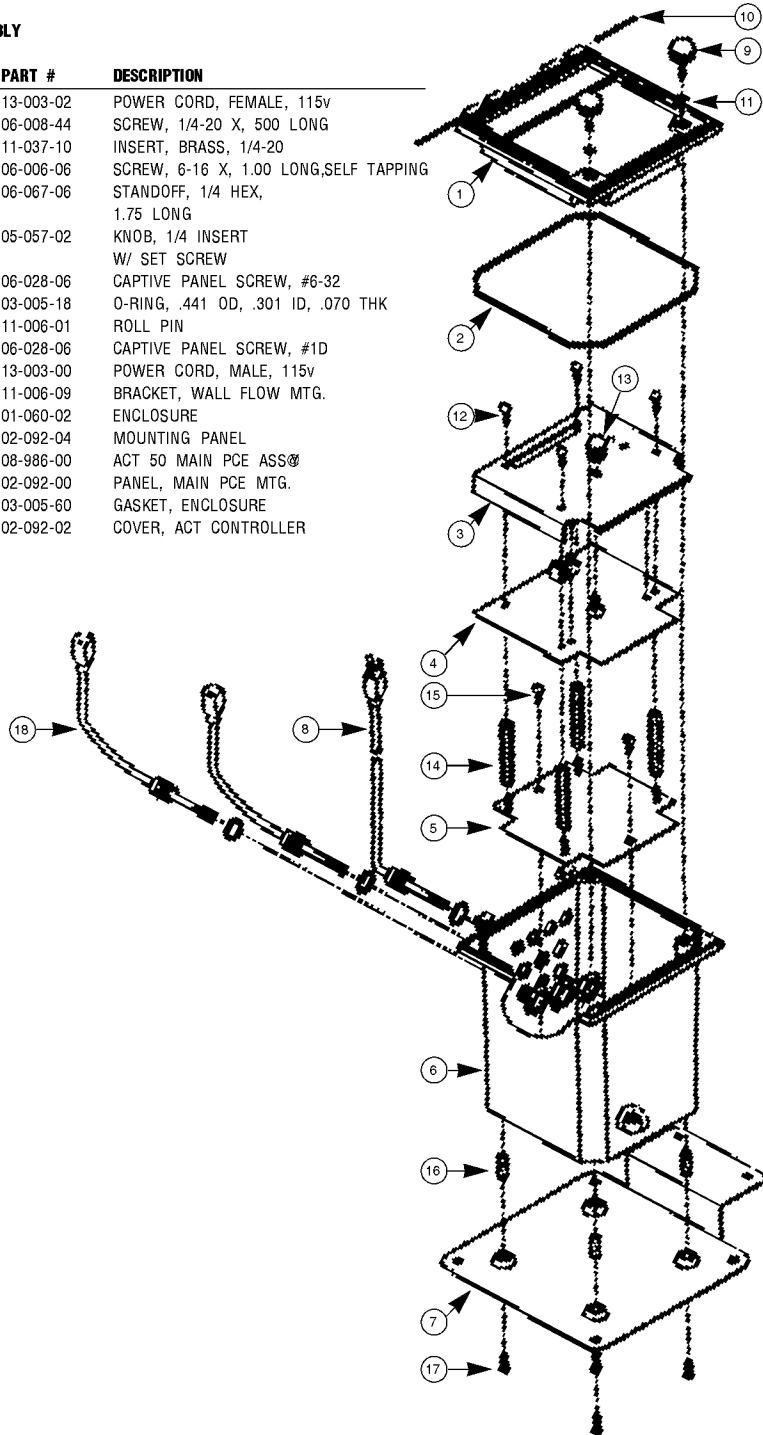

## ELECTRODE ASSEMBLY

ITEM	QUAN.	PART #	DESCRIPTION
7	1	20-110-02	CAUTION TAG, PVC ADAPTERS
6	2	03-093-00	3/4 MALE ADAPTER, PVC
5	1	03-096-56	TEE, FLOW, PPY
4	1	03-005-04	GASKET, O-RING, #2-029
3	1	03-005-02	GASKET, O-RING, #2-119
2	1	04-300-16	ELECTRODE ASSY., CN-1A, 10'
1	1	06-008-00	COUPLING NUT
	1	312.005	LITTLE FUSE 5 AMP, 250V, 1/4 x 1-1/4, FAST BLOW
	1	312.001	LITTLE FUSE 1 AMP, 250V, 1/4 x 1-1/4, FAST BLOW

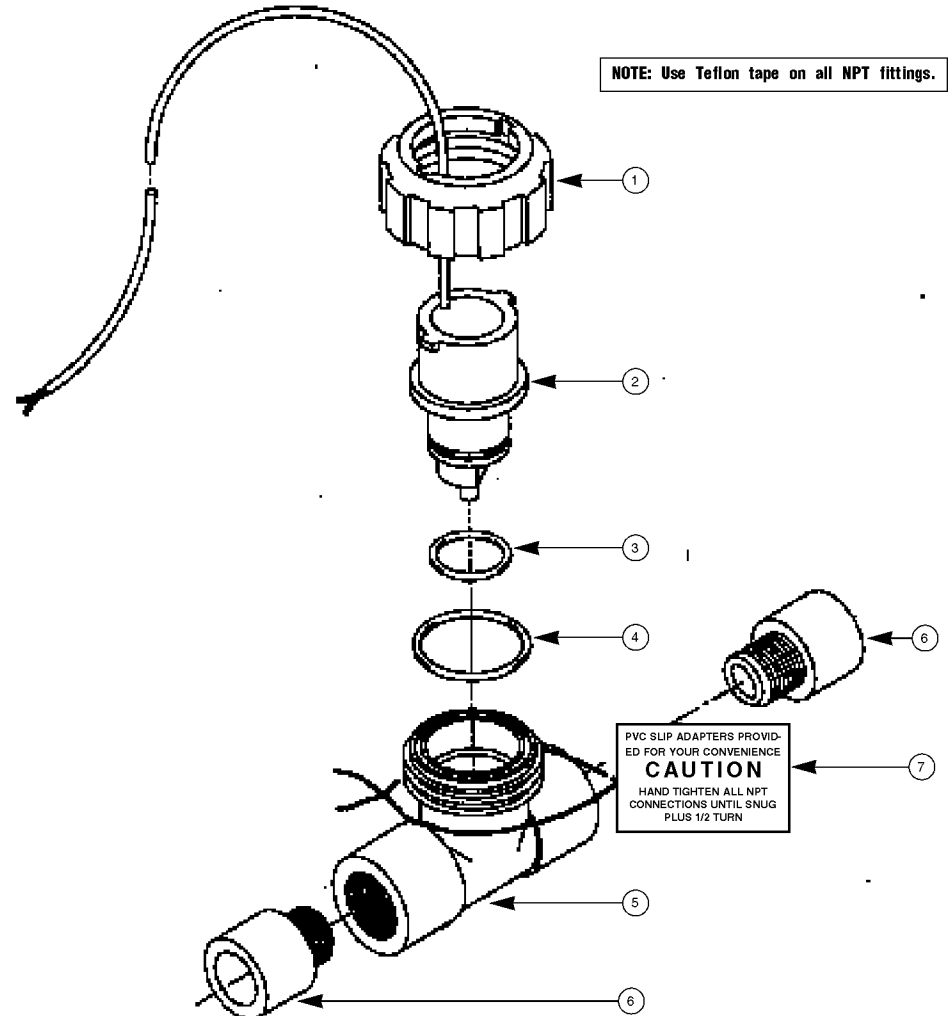

## 8. ACT COOLING TOWER CONTROLLER SERIES

### A. KEY FEATURES:

- Front panel calibration.
- Front panel dial set point.
- Conductivity range 0-5,000  $\mu\text{S}/\text{cm}$ .
- Blow down and or metering pump indicator LED.
- Relay test switch.
- Power indicator LED.
- Pre-wired output connections (conduit optional).
- Weather-tight enclosure designed to NEMA 2 and NEMA 4X, option A only.
- Wall mountable.

### B. ACT MODEL STANDARD FEATURES:

ACT 50	Dial conductivity controller 0-5,000 $\mu\text{S}/\text{cm}$
ACT 101	Dial conductivity controller selectable dual scale 0-2,500 $\mu\text{S}/\text{cm}$ and 0-5,000 $\mu\text{S}/\text{cm}$
ACT 102	Analog meter conductivity controller selectable dual scale 0-2,500 $\mu\text{S}/\text{cm}$ and 0-5,000 $\mu\text{S}/\text{cm}$

### C. OPTIONS:

		<b>SERIES AVAILABLE</b>
A	Conduit	50/101/102
B	Mounted flow switch	101/102
C	Lockout timer	101/102
D	Pulse timer	101/102
M	4-20 mA Isolated output	101/102
P	230 VAC @ 50/60 Hz service (requires option A)	50/101/102