

MEC-O-MATIC

2400T Series

Metering Pumps
Grease Trap Dispensers

PULSAFEEDER[®]
A Unit of IDEX Corporation

2400T Series Metering Pumps / Grease Trap Dispensers

are capable to dispensing low volumes of chemicals, detergents, liquid enzymes, fragrances and bio-chemicals. Programmable for use in difficult drain/grease cleaning situations.

The impedance protected gearmotor is safe, quiet and dependable. All metal gearing parts are heat-treated and the output shaft is supported by heavy duty bearings.

The 2400T-DC is battery powered for added safety and convenience. The pump is designed for extended battery life and runs on easy-to-install, economical D-size batteries, (Batteries not included), with a visual, low battery indicator built in.

2400T and 2400T Plus gearmotors are also available for 240V 60Hz operation.

The pump case on the 2400T and 2400T Plus is molded of a rugged chemical resistant ABS. An available option for the 2400T Plus is a lockable latch cover. The 2400T-DC is in an enclosed rugged chemical resistant ABS case. Mounting pads and a built-in wall mounting bracket allow choice of flat surface or wall mounted installation.

The 2400T features a 24-hour day timer which provides 96 settings in 15 minute increments. The 2400T Plus and 2400T-DC feature a quartz-driven time switch with large LCD display showing time, day, switching programs, and program status with a manual override provided. Timer has 8 on/off settings per day, available for daily or weekly programming and can be programmed down to one-minute increments. A lithium battery provides minimum 5-year backup.

Optional tubing materials are available for special chemical applications and higher outputs.

Key Features

- Capable of Dispensing Low Volumes
- Programmable
- Simple Installation
- Prime Push Button for Quick Start-Up
- Quick Release Twist Off Head
- Built-In Timer
- No Tube Adjustment Needed
- Self Lubricating Roller Assembly



2400T Series Specifications

Specifications

Model		2400T	2400T DC	2400T Plus
Timer		Mechanical	Programmable Microprocessor	Programmable Microprocessor
Nominal Feed Rate	24 hrs.	2.5 gal	NA	2.5 gal
	1 hr.	13.2 oz	NA	13.2 oz
	15 min	3.3 oz	NA	3.3 oz
	1 min	NA	3.0 oz	.22 oz
Head		Polycarbonate		
Tubing		Silicone or Viton	Norprene	Silicone or Viton
Pressure (max.)		25 psi		
Electrical Requirements		120 VAC	12V DC	120 VAC

Typical Installation

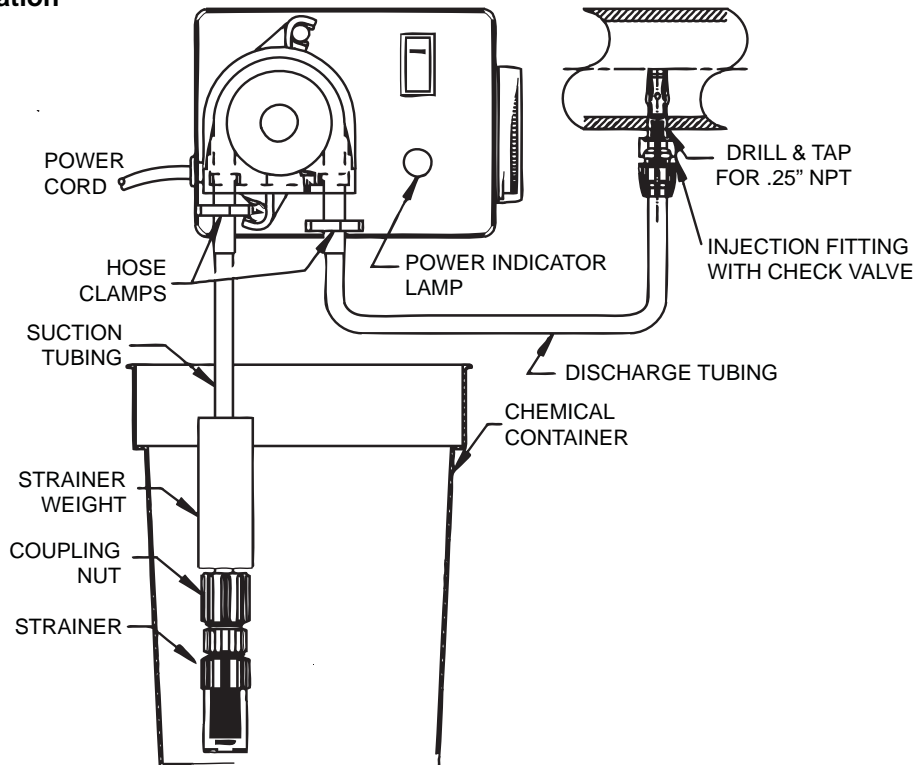

Dimensions

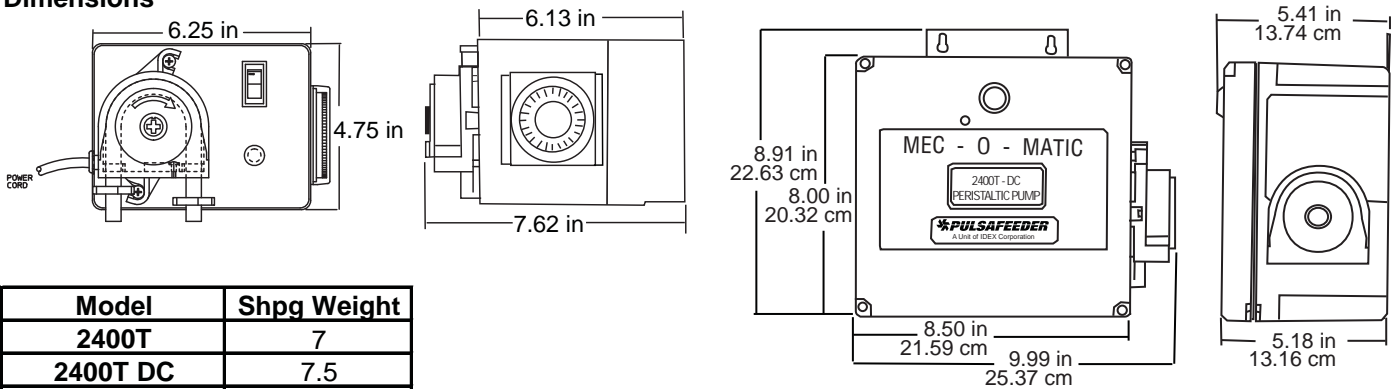

Model	Shpg Weight
2400T	7
2400T DC	7.5
2400T Plus	7



An ISO Certified Company

IDEX
IDEX CORPORATION
MOM005 K08

PULSAFEEDER

A Unit of IDEX Corporation

Standard Product Operations

27101 Airport Road • Punta Gorda, Florida 33982
TEL (941) 575-3800 • TEL 800-333-6677
FAX (941) 575-4085 • FAX 800-456-4085
spottech@pulsa.com • www.pulsa.com